

Digital Pressure Switch



RoHS compliant

Low profile **9.8 mm**



Vertical mounting space reduced to approx. **1/2!**

Reduced in depth!

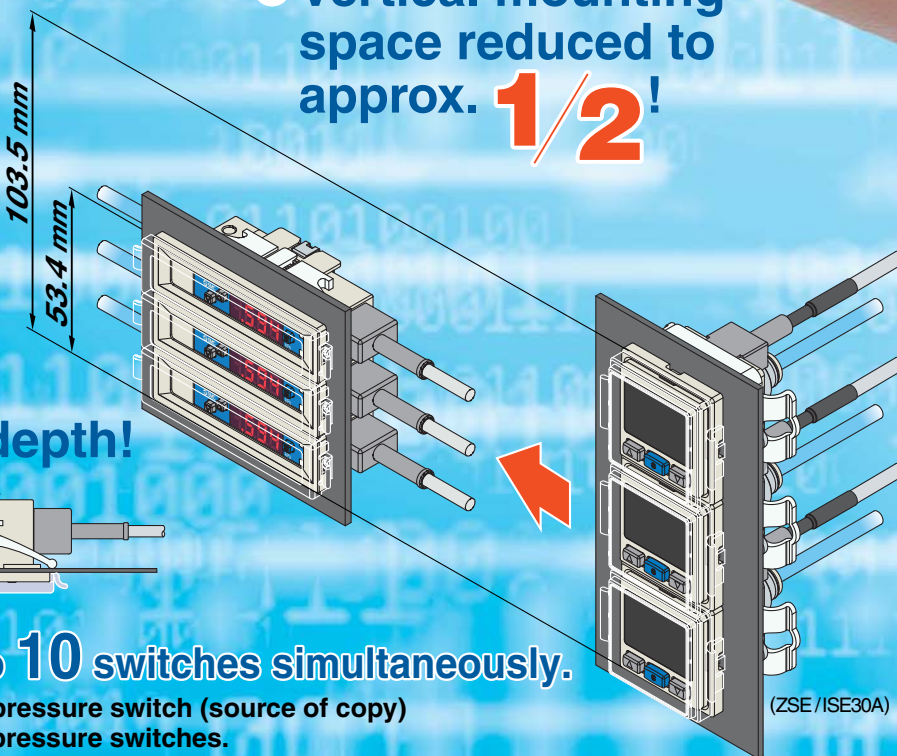
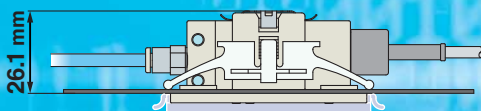

Can copy to up to 10 switches simultaneously.

The settings of the master pressure switch (source of copy) can be copied to the slave pressure switches.

Reduction in setting work • Prevention of mistakes in setting

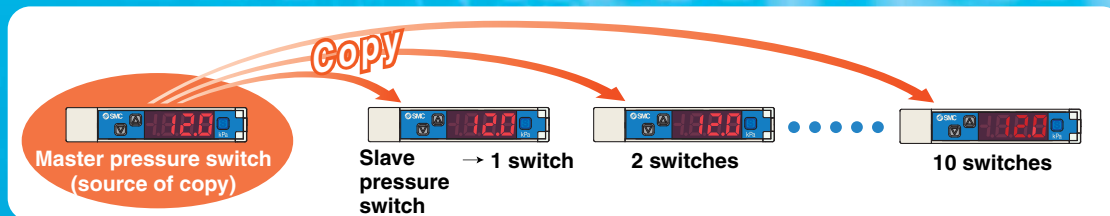

3-step setting

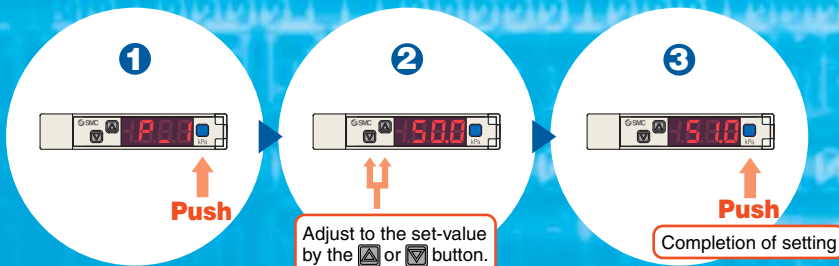

Series **ZSE10(F)/ISE10**



CAT.ES100-75A

Improved visibility from multiple directions

The vacuum suction and burst pressure can be checked at a glance by indicator lights.

Multi-angle indicator

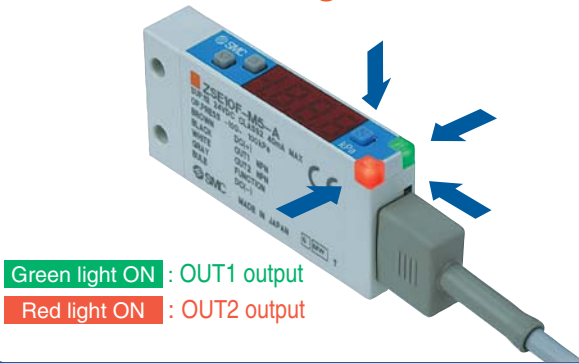

<Application example>

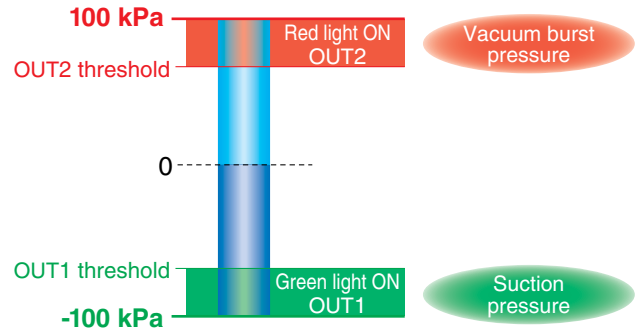

Mounting

Direct mounting

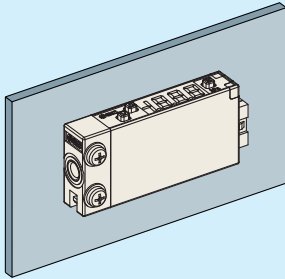

Panel mounting

Can be mounted closely in vertical direction.
One opening for all!

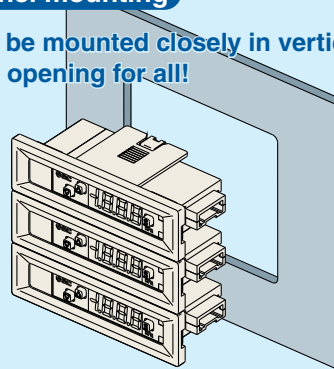

DIN rail mounting

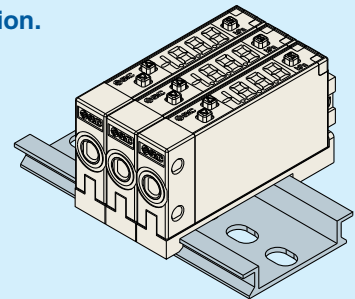

Piping is possible from two directions.

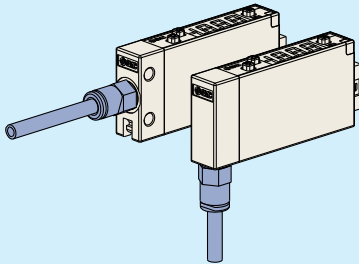

Pressure range of the positive pressure type expanded to vacuum area.

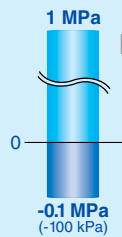

Rated pressure range:
-0.100 to 1.000 MPa

Standardized 2-output type.

- NPN or PNP open collector 2 outputs
- NPN or PNP open collector 1 output + Analog output (1 to 5 V)

Resolution conversion function

The flickering on the display can be eliminated.



(Only the displayed value is changed, and there is no effect on the accuracy.)

Secret code setting function

A function to prevent operation by anyone other than the designated operator while the keys are locked.

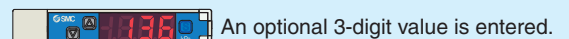

The set-value can be checked while the keys are locked.)

Power-saving function

The display can be turned off to save the power consumption.

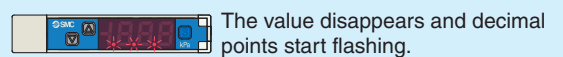

(Power consumption reduced by max 20%)

Series	ZSE10 (vacuum pressure)	ZSE10F (compound pressure)	ISE10 (positive pressure)
Rated pressure voltage	0.0 to -101.0 kPa -101 kPa	-100.0 to 100.0 kPa 100 kPa -100 kPa	-0.100 to 1.000 MPa 1 MPa -0.1 MPa (-100 kPa)
Set pressure range	10.0 to -105.0 kPa	-105.0 to 105.0 kPa	-0.105 to 1.050 MPa
Withstand pressure	500 kPa	500 kPa	1.5 MPa
Min. unit setting	0.1 kPa	0.1 kPa	0.001 MPa
Output	NPN or PNP open collector 2 outputs NPN or PNP open collector 1 output + Analog output (voltage)		

Digital Pressure Switch

Series ZSE10(F)/ISE10

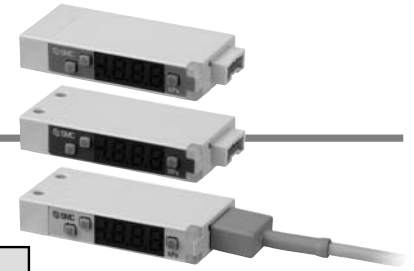

How to Order

For positive pressure

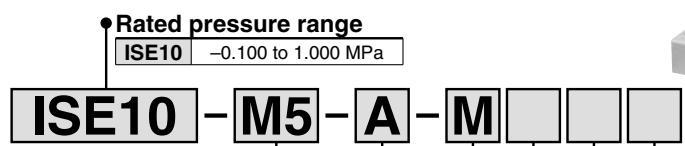

For vacuum/
compound pressure



Rated pressure range

ZSE10	0.0 to -101.0 kPa
ZSE10F	-100.0 to 100 kPa

Option 3

Symbol	Calibration certificate
Nil	—
K	○

Piping specifications

M5	M5 female thread/Side ported Piping port	
M5R	M5 female thread/Rear ported Piping port	
01*	R1/8/Side ported R1/8 Piping adapter	
N01*	NPT1/8/Side ported NPT1/8 Piping adapter	

Option 2

Nil	None
D Note 3)	Panel mount adapter + Front protective cover
R Note 4)	DIN rail adapter Note 5)

Output specifications

A	NPN open collector 2 outputs
B	PNP open collector 2 outputs
C*	NPN open collector 1 output + Analog voltage
E*	PNP open collector 1 output + Analog voltage

* Made to Order

Option 1

Nil	Without lead wire	
G	Lead wire with connector (Lead wire length: 2 m) With connector cover	

Unit specifications

Nil	With unit switching function Note 1)
M	Fixed SI unit Note 2)
P	With unit switching function Note 1) (Initial value psi)

Note 1) Under the New Measurement Law, sales of switches with the unit switching function are not allowed for use in Japan.

Note 2) Fixed unit:
For vacuum/compound pressure: kPa
For positive pressure: MPa

Note 3) Not available for piping specifications of 01 and N01.
Note 4) Not available for piping specifications of M5R, 01 and N01.
Note 5) The DIN rail needs to be prepared by the customer.

Options/Part No.

When optional parts are required separately, use the following part numbers to place an order.

Part no.	Option
ZS-39-5G	Lead wire with connector (with connector cover) (5 cores, 2 m)
ZS-39-B	Panel mount adapter
ZS-39-D	Panel mount adapter + Front protective cover
ZS-39-R	DIN rail adapter

Part no.	Option
ZS-39-01	Front protective cover
ZS-39-N1*	R1/8 piping adapter
ZS-39-N2*	NPT1/8 piping adapter

* Made to Order



Series ZSE10(F)/ISE10

Specifications

Model	ZSE10 (vacuum pressure)	ZSE10F (compound pressure)	ISE10 (positive pressure)
Rated pressure range	0.0 to -101.0 kPa	-100.0 to 100.0 kPa	-0.100 to 1.000 MPa
Set pressure range/Pressure display range	10.0 to -105.0 kPa	-105.0 to 105.0 kPa	-0.105 to 1.050 MPa
Withstand pressure	500 kPa	500 kPa	1.5 MPa
Minimum unit setting	0.1 kPa	0.1 kPa	0.001 MPa
Fluid	Air, Inert gas, Non-flammable gas		
Power supply voltage	12 to 24 VDC $\pm 10\%$, Ripple (p-p) 10% or less (With power supply polarity protection)		
Current consumption	40 mA or less		
Switch output	NPN or PNP open collector 2 outputs (Selectable)		
	Maximum load current	80 mA	
	Maximum applied voltage	28 V (With NPN output)	
	Residual voltage	2 V or less (With load current of 80 mA)	
	Response time	2.5 ms or less (Response time selections with anti-chattering function: 20, 100, 500, 1000, 2000 ms)	
	Short circuit protection	Yes	
Repeat accuracy	$\pm 0.2\%$ F.S. ± 1 digit		
Hysteresis	Hysteresis mode	Variable (0 or above) ^{Note}	
	Window comparator mode		
Analog output	Output voltage (Rated pressure range)	1 to 5 V $\pm 2.5\%$ F.S.	0.6 to 5 V $\pm 2.5\%$ F.S.
	Linearity	$\pm 1\%$ F.S. or less	
	Output impedance	Approx. 1 k Ω	
Display	3 1/2 digit, 7-segment indicator, 1-color display (Red)		
Display accuracy	$\pm 2\%$ F.S. ± 1 digit (at 25°C $\pm 3^\circ\text{C}$ ambient temperature)		
Indicator light	Lights up when output is turned ON. OUT1: Green OUT2: Red		
Environmental resistance	Enclosure	IP40	
	Operating temperature range	Operating: -5 to 50°C, Stored: -10 to 60°C (No freezing or condensation)	
	Operating humidity range	Operating and stored: 35 to 85% RH (No condensation)	
	Withstand voltage	1000 VAC for 1 min. between live parts and enclosure	
	Insulation resistance	50 M Ω or more between live parts and enclosure (at 500 VDC Mega)	
	Vibration resistance	10 to 150 Hz, at the smaller of amplitude 1.5 mm or 20 m/s ² in X, Y, Z directions for 2 hours each (De-energized)	
Impact resistance	100 m/s ² in X, Y, Z directions 3 times each (De-energized)		
Temperature characteristics	$\pm 2\%$ F.S. (at 25°C in an operating range of -5 to 50°C)		
Lead wire	Oil-resistant vinyl cable 5 cores, Cross section: 0.15 mm ² (AWG26) Insulator O.D.: 1.0 mm		
Standard	Compliant with CE Marking and RoHS compliant		

Note) If the applied voltage fluctuates around the set-value, the hysteresis must be set to a value more than the fluctuating width, otherwise chattering will occur.

Piping Specifications

Model	M5	M5R	O1	N01
Port size	M5 x 0.8 (Side ported)	M5 x 0.8 (Rear ported)	R1/8 (Side ported)	NPT1/8 (Side ported)
Wetted part material	Sensor pressure receiving area	Sensor pressure receiving area: Silicon		
	Piping port	C3604 (Electroless nickel plated) O-ring: HNBR		
Mass	With lead wire with connector (5 cores, 2 m)	55 g		63 g
	Without lead wire with connector	15 g		23 g

Function (Details \Rightarrow Pages 8 and 9)

Copy function	The settings of the master pressure switch can be copied to the slave pressure switches.
Auto-preset function	This function is to calculate a rough set value automatically based on the on-going operation.
Precision indicator setting function	The scattering of the indicated value can be eliminated.
Peak display function	Can retain the maximum pressure value displayed during measurement.
Bottom display function	Can retain the minimum pressure value displayed during measurement.
Key lock function (Selectable secret code)	Key operation can be locked to prevent any incorrect function of the operation switch.
Zero-clear function	The pressure display can be set at zero when the pressure is open to the atmosphere.
Anti-chattering function	Prevents possible malfunction due to sudden fluctuations in the primary pressure by adjusting the response time.
Display unit switching function	Can convert the display value.
Power-saving mode	Reduces power consumption.
Display resolution conversion function	Changes the display resolution from the default value 1000 to 100. The flickering on the display can be eliminated.
kPa \leftrightarrow MPa conversion function	The unit can be changed between kPa and MPa.

Analog Output

Voltage output

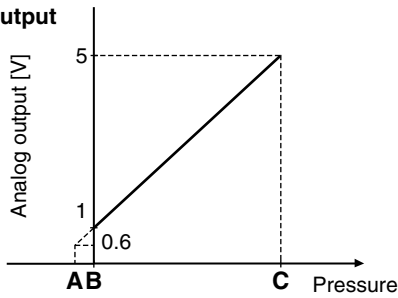

Range	Rated pressure range	A	B	C
For vacuum pressure	0.0 to -101.0 kPa	—	0	-101 kPa
For compound pressure	-100.0 to 100.0 kPa	—	-100 kPa	100 kPa
For positive pressure	-0.100 to 1.000 MPa	-0.1 kPa	0	1 MPa

Descriptions

Output (OUT1) indicator (Green)	Lights up when switch output (OUT1) is turned ON.
Output (OUT2) indicator (Red)	Lights up when switch output (OUT2) is turned ON.
LED	Displays the current pressure, set mode, and error code.
▲ button (UP)	Use this button to select the mode or increase the ON/OFF set-value. Use this button to switch to the peak display mode.
▼ button (DOWN)	Use this button to select the mode or decrease the ON/OFF set-value. Use this button to switch to the bottom display mode.
Ⓢ button (SET)	Use this button to change the mode or finalize the set-value.

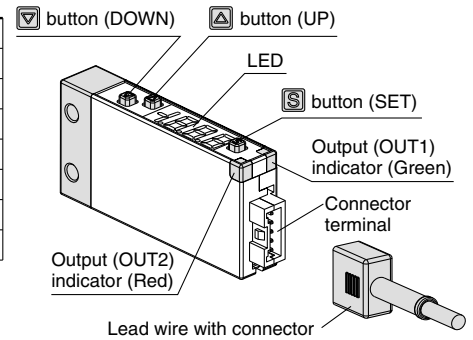

Internal Circuits and Wiring Examples

ZSE10(F)/ISE10 - [] - [] - [] - [] - []

● Output specifications

A

NPN (2 outputs)

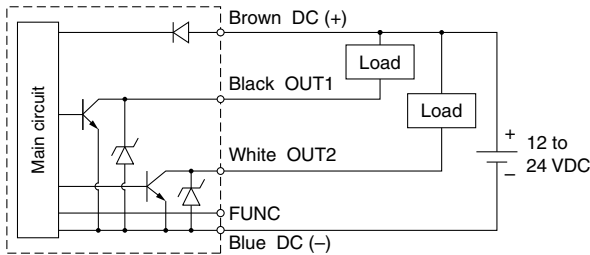

Max. 28 V, 80 mA
Residual voltage 2 V or less

B

PNP (2 outputs)

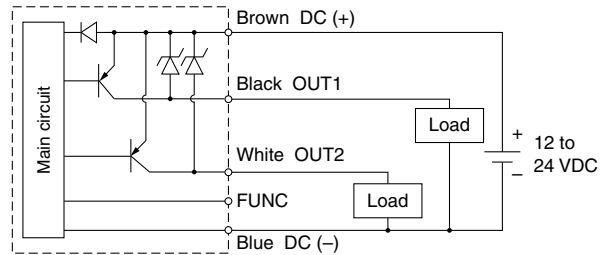

Max. 80 mA
Residual voltage 2 V or less

C

NPN (1 output) + Analog voltage output

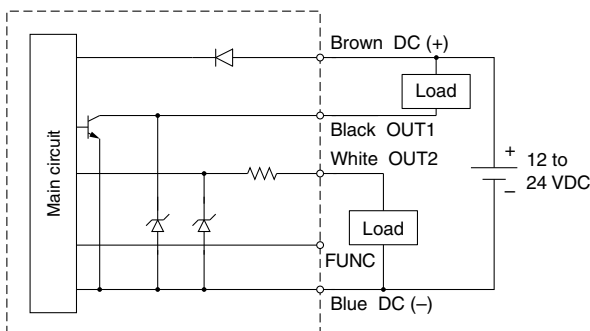

Max. 28 V, 80 mA
Residual voltage 2 V or less
Analog voltage output
Output impedance approx. 1 kΩ

E

PNP (1 output) + Analog voltage output

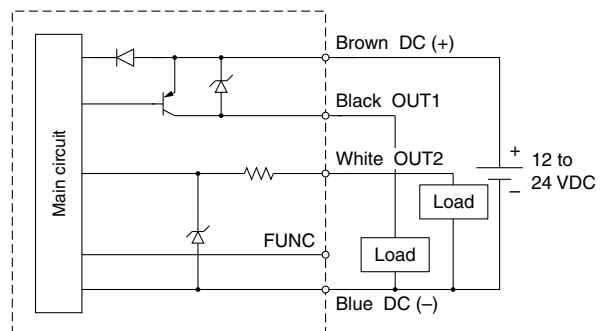

Max. 80 mA
Residual voltage 2 V or less
Analog voltage output
Output impedance approx. 1 kΩ

* The FUNC terminal is connected when using the copy function. (Refer to "Copy function" on page 8.)

Series ZSE10(F)/ISE10

Dimensions

ZSE10(F)/ISE10 - M5 - □ - □ □ □ □

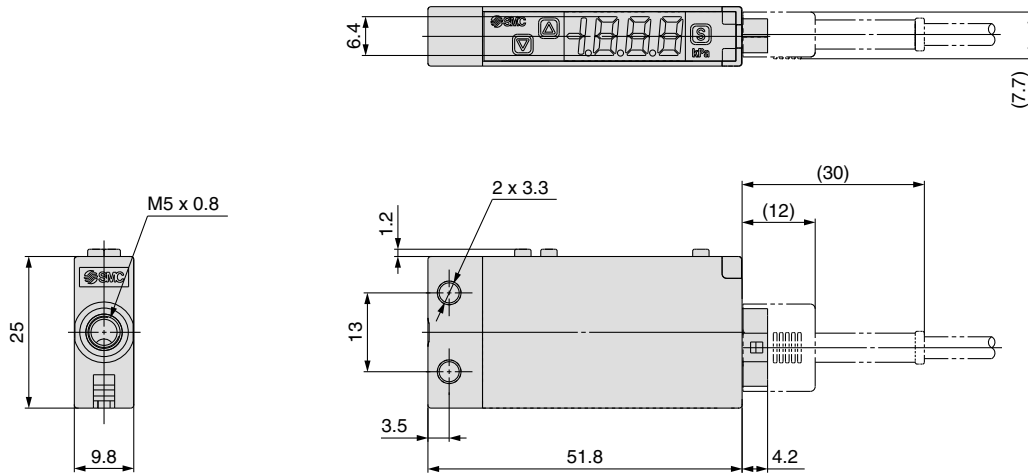

ZSE10(F)/ISE10 - M5R - □ - □ □ □ □

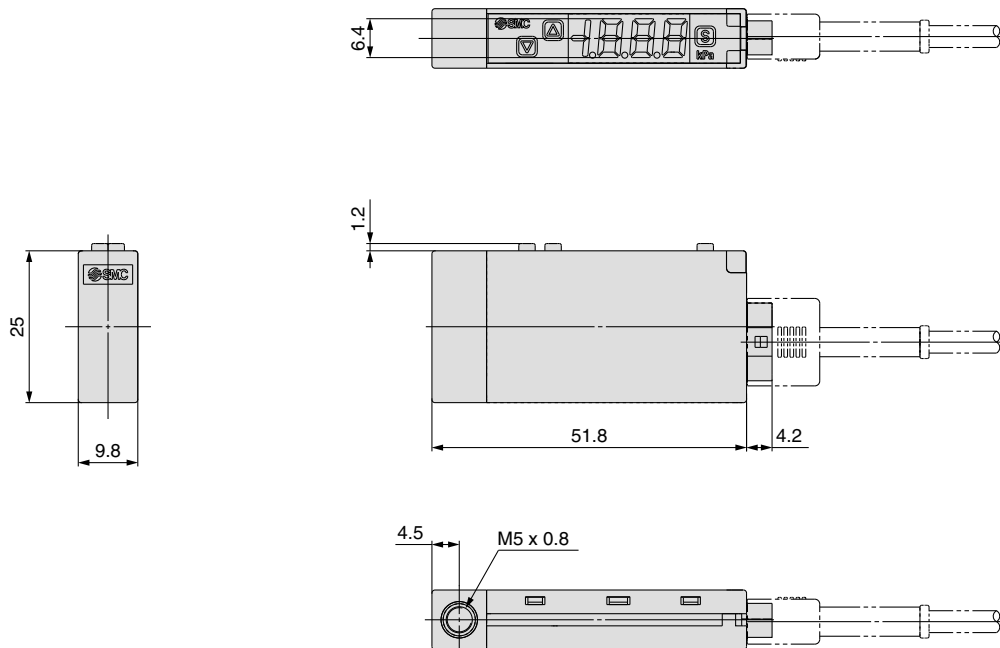

ZSE10(F)/ISE10 - 01 - -

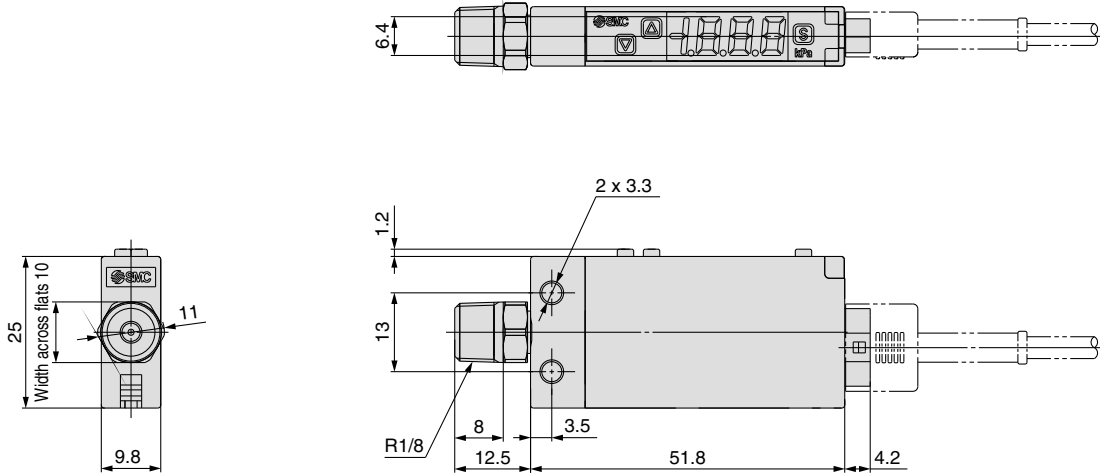

ZSE10(F)/ISE10 - N01 - -

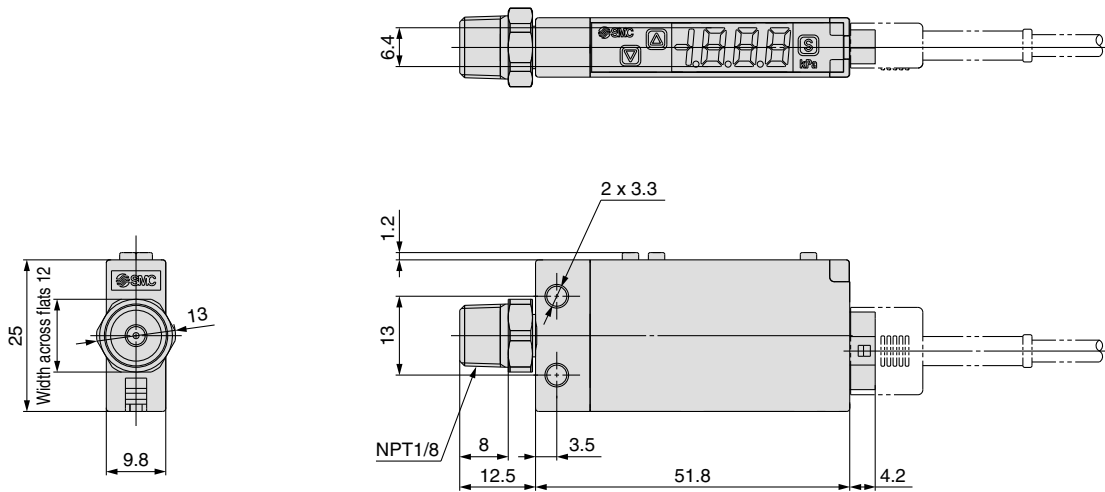

Series ZSE10(F)/ISE10

Dimensions

ZSE10(F)/ISE10 - M5 - □ - □ □ D □

Panel mount adapter + Front protective cover

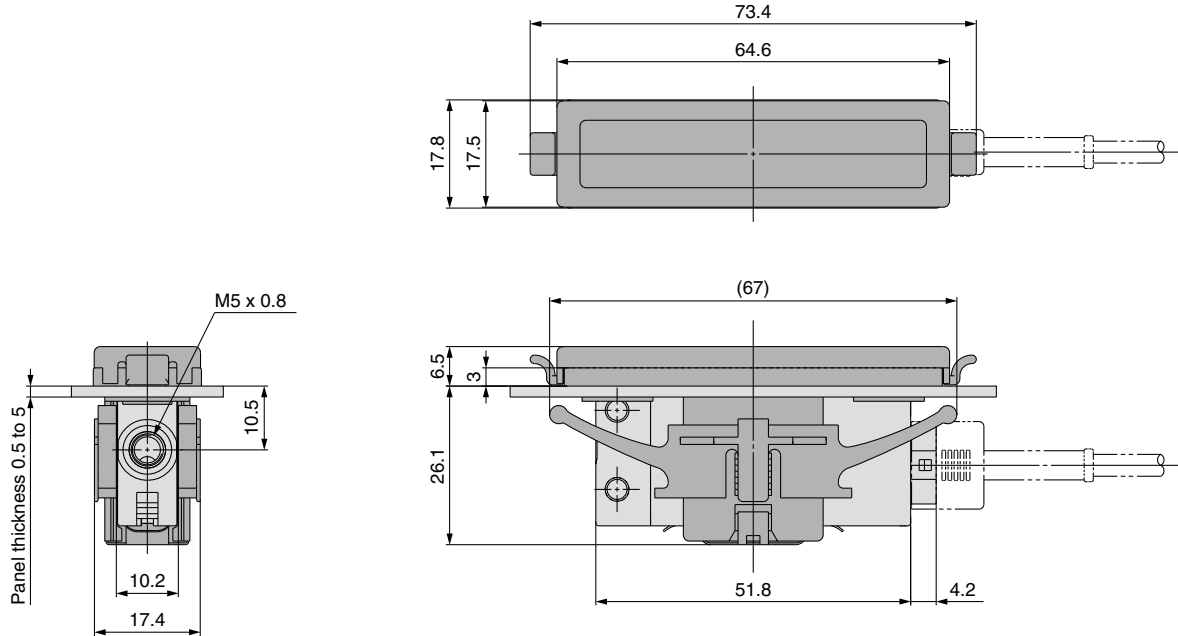

ZSE10(F)/ISE10 - M5R - □ - □ □ D □

Panel mount adapter + Front protective cover

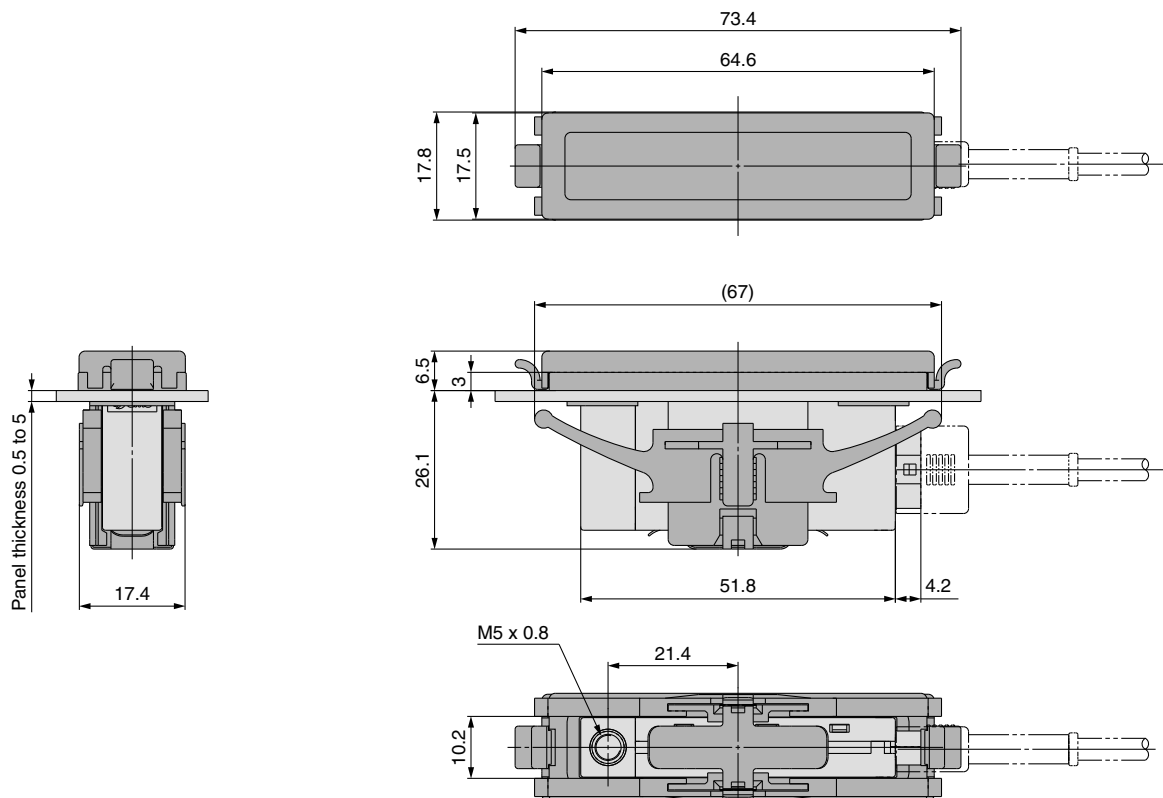

Panel fitting dimensions

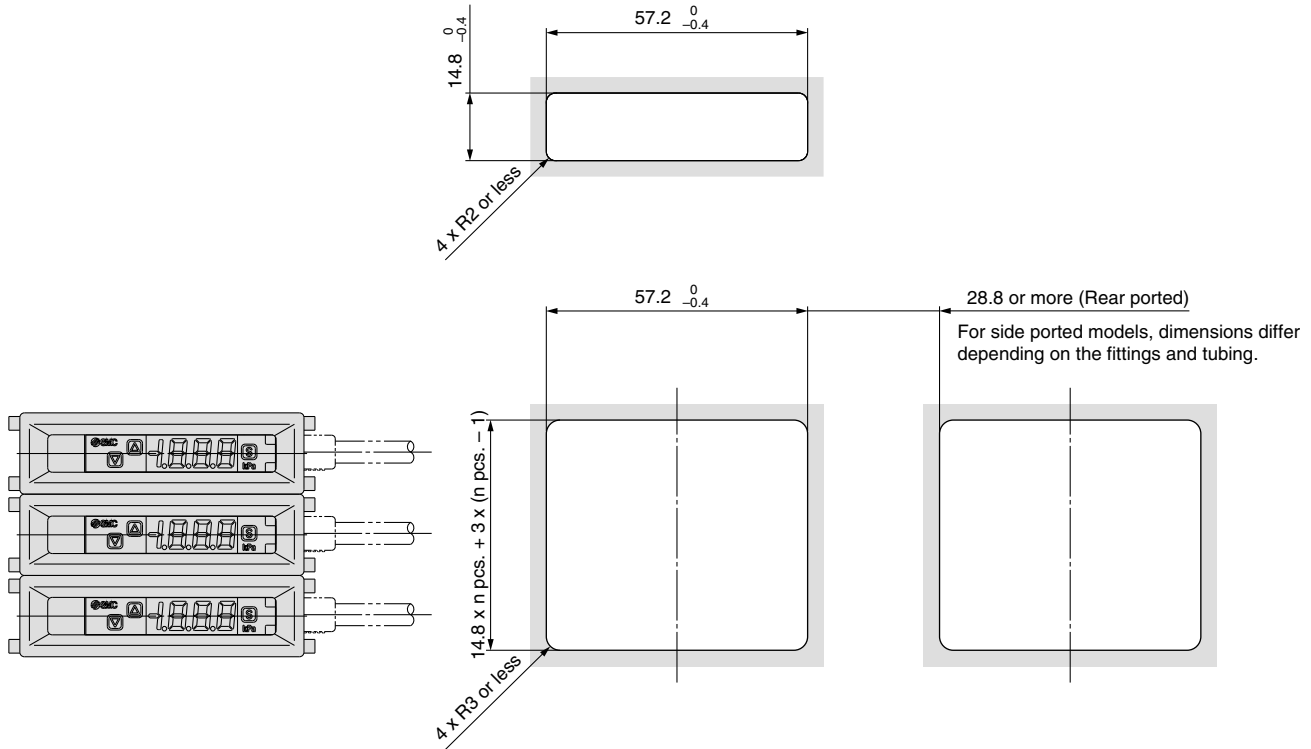

ZSE10(F)/ISE10 - M5 - □ - □ □ R □

With DIN rail

The DIN rail needs to be prepared by the customer.

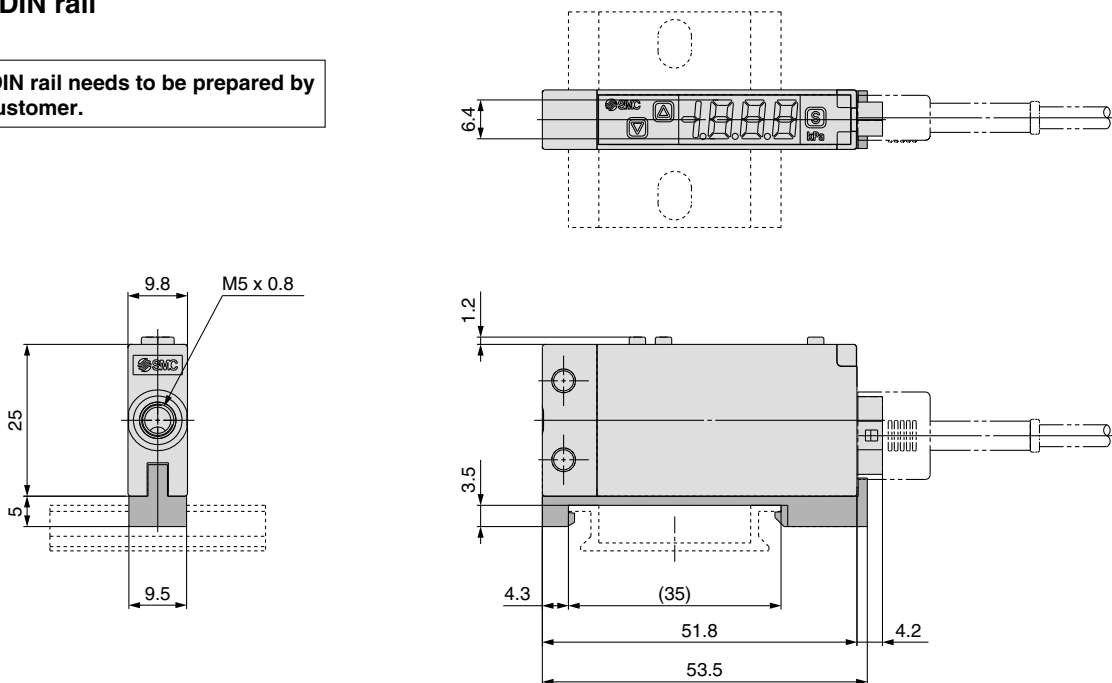

Function Details

A Copy function (F97)

The settings of the master pressure switch can be copied to the slave pressure switches. This can reduce the labor for setting and prevent the entry of incorrect set-values.

The set-value can be copied to up to 10 switches simultaneously.
(Maximum communication distance 4 m)

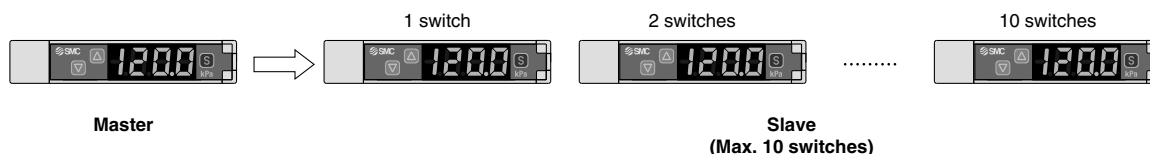

- 1) Connect the power supply and copy line as shown in the left figure.
- 2) Select the slave switch which is to be the master, and change it into a master using the buttons. (In the default setting, all switches are set as slaves.)
- 3) Press the button of the master switch to start copying.

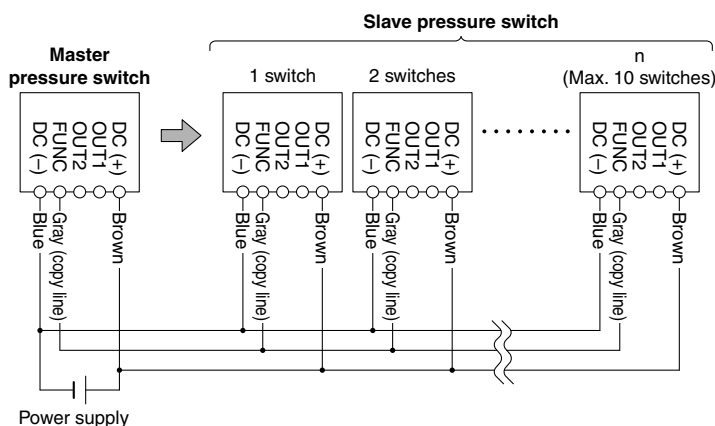

B Auto-preset function (F 5)

Auto-preset function, when selected in the initial setting, calculates and stores the set-value from the measured pressure. The optimum set-value is determined automatically by repeating vacuum and break with the target workpiece several times.

Suction Verification

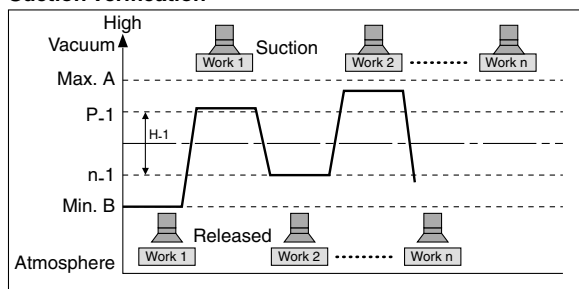

Formula for Obtaining the Set-Value

P ₁ or P ₂	H ₁ or H ₂
$P_1 (P_2) = A - (A-B)/4$	$H_1 (H_2) = (A-B)/2$
$n_1 (n_2) = B + (A-B)/4$	

C Precision indicator setting function (F 6)

Fine adjustment of the indicated value of the pressure sensor can be made within the range of $\pm 5\%$ of the read value. (The scattering of the indicated value can be eliminated.)

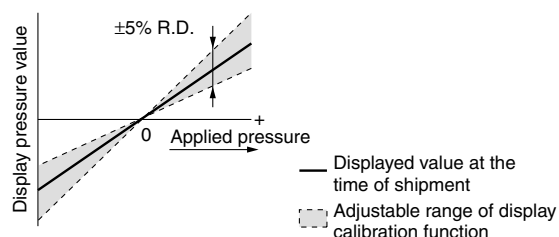

Note) When the precision indicator setting function is used, the set pressure value may change ± 1 digit.

D Peak and bottom display function

This function constantly detects and updates the maximum (minimum) value and allows to hold the maximum (minimum) pressure value.

When the buttons are simultaneously pressed for 1 second or longer, while "holding", the hold value will be reset.

E Key lock function

This function prevents incorrect operations such as accidentally changing the set-value.

F Zero-clear function

This function clears and resets the zero value on the display of measured pressure.

For the pressure switch with analog output, the analog output shifts according to the indication. A displayed value can be adjusted within $\pm 7\%$ F.S. of the pressure when ex-factory. (ZSE10F (for compound pressure) $\pm 3.5\%$ F.S.)

The F□ in () shows the function code number. Refer to the Operation Manual for the details of operation procedures and function codes.

G Error indication function

Error name	Error code	Description	Remedy
Overcurrent error	Er1	Load current of switch output (OUT1) exceeds 80 mA.	Turn the power off and remove the output factor for the over current. Then turn the power on.
	Er2	Load current of switch output (OUT2) exceeds 80 mA.	
Zero-clear error	Er3	During zero-clear operation, pressure over $\pm 7\%$ F.S. is applied. (ZSE10F (compound) $\pm 3.5\%$ F.S.) After 1 s, the mode will reset to measurement mode. $\pm 1\%$ F.S. of the zero-clear range varies between individual products.	Perform zero-clear operation again after restoring the applied pressure to an atmospheric pressure
Applied pressure error	HHH	Supply pressure exceeds the maximum set pressure.	Reset applied pressure to a level within the set pressure range.
	LLL	Supply pressure is below the minimum set pressure.	
System error	Er0	Internal data error	Turn the power off and turn it on again. If the failure cannot be solved, ask SMC for repair.
	Er4		
	Er6		
	Er7		
	Er8		
	Er9		

If the above remedy cannot recover the operation, ask SMC for repair.

H Anti-chattering function (F 3)

A large bore cylinder or ejector consumes a large volume of air in operation and may experience a temporary drop in the supply pressure. This function prevents detection of such temporary drops in the supply pressure as an error.

Available response time settings
20 ms, 100 ms, 500 ms, 1000 ms, 2000 ms

<Principle>

This function averages pressure values measured during the response time set by the user and then compares the average pressure value with the pressure set point value to output the result on the switch.

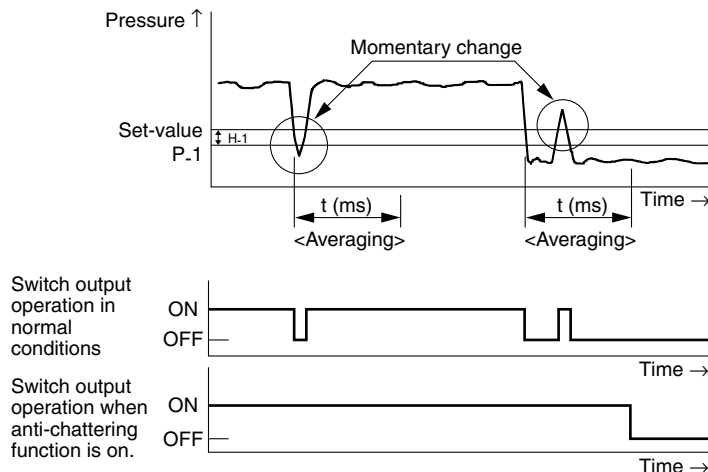

I Display unit switching function (F 0)

Display units can be switched with this function.

Display unit Min. unit setting	PA		GF	bAr	PSi	inH	mmH
	kPa	MPa*	kgf/cm ²	bar	psi	inHg	mmHg
ZSE10 (vacuum pressure)	0.1	0.001	0.001	0.001	0.01	0.1	1
ZSE10F (compound pressure)	0.1	0.001	0.001	0.001	0.02	0.1	1
ISE10 (positive pressure)	1	0.001	0.01	0.01	0.1		

* The ZSE10 (vacuum pressure) and ZSE10F (compound pressure) will have different setting and display resolution when the unit is set to MPa.

J Power-saving mode (F80)

Power-saving mode can be selected.

It shifts to the power-saving mode without button operation for 30 seconds. It is set to the normal mode (Power-saving mode is OFF.) when ex-factory. (Decimal points and operation indicator light (only when the switch output is turned ON.) blink in the power-saving mode.)

K Secret code setting (F81)



It can be set whether code number input is required or not when key is locked. It is set to input no code number when ex-factory.



Safety Instructions

These safety instructions are intended to prevent hazardous situations and/or equipment damage. These instructions indicate the level of potential hazard with the labels of “**Caution,**” “**Warning**” or “**Danger.**” They are all important notes for safety and must be followed in addition to International Standards (ISO/IEC)*1), and other safety regulations.

*1) ISO 4414: Pneumatic fluid power – General rules relating to systems.
ISO 4413: Hydraulic fluid power – General rules relating to systems.
IEC 60204-1: Safety of machinery – Electrical equipment of machines. (Part 1: General requirements)
ISO 10218-1: Manipulating industrial robots - Safety.
etc.

-  **Caution:** **Caution** indicates a hazard with a low level of risk which, if not avoided, could result in minor or moderate injury.
-  **Warning:** **Warning** indicates a hazard with a medium level of risk which, if not avoided, could result in death or serious injury.
-  **Danger :** **Danger** indicates a hazard with a high level of risk which, if not avoided, will result in death or serious injury.

Warning

1. The compatibility of the product is the responsibility of the person who designs the equipment or decides its specifications.

Since the product specified here is used under various operating conditions, its compatibility with specific equipment must be decided by the person who designs the equipment or decides its specifications based on necessary analysis and test results. The expected performance and safety assurance of the equipment will be the responsibility of the person who has determined its compatibility with the product. This person should also continuously review all specifications of the product referring to its latest catalog information, with a view to giving due consideration to any possibility of equipment failure when configuring the equipment.

2. Only personnel with appropriate training should operate machinery and equipment.

The product specified here may become unsafe if handled incorrectly. The assembly, operation and maintenance of machines or equipment including our products must be performed by an operator who is appropriately trained and experienced.

3. Do not service or attempt to remove product and machinery/equipment until safety is confirmed.

1. The inspection and maintenance of machinery/equipment should only be performed after measures to prevent falling or runaway of the driven objects have been confirmed.
2. When the product is to be removed, confirm that the safety measures as mentioned above are implemented and the power from any appropriate source is cut, and read and understand the specific product precautions of all relevant products carefully.
3. Before machinery/equipment is restarted, take measures to prevent unexpected operation and malfunction.

4. Contact SMC beforehand and take special consideration of safety measures if the product is to be used in any of the following conditions.

1. Conditions and environments outside of the given specifications, or use outdoors or in a place exposed to direct sunlight.
2. Installation on equipment in conjunction with atomic energy, railways, air navigation, space, shipping, vehicles, military, medical treatment, combustion and recreation, or equipment in contact with food and beverages, emergency stop circuits, clutch and brake circuits in press applications, safety equipment or other applications unsuitable for the standard specifications described in the product catalog.
3. An application which could have negative effects on people, property, or animals requiring special safety analysis.
4. Use in an interlock circuit, which requires the provision of double interlock for possible failure by using a mechanical protective function, and periodical checks to confirm proper operation.



Safety Instructions

Caution

1. The product is provided for use in manufacturing industries.

The product herein described is basically provided for peaceful use in manufacturing industries.

If considering using the product in other industries, consult SMC beforehand and exchange specifications or a contract if necessary.

If anything is unclear, contact your nearest sales branch.

Limited warranty and Disclaimer/Compliance Requirements

The product used is subject to the following “Limited warranty and Disclaimer” and “Compliance Requirements”. Read and accept them before using the product.

Limited warranty and Disclaimer

1. The warranty period of the product is 1 year in service or 1.5 years after the product is delivered.*2)

Also, the product may have specified durability, running distance or replacement parts. Please consult your nearest sales branch.

2. For any failure or damage reported within the warranty period which is clearly our responsibility, a replacement product or necessary parts will be provided.

This limited warranty applies only to our product independently, and not to any other damage incurred due to the failure of the product.

3. Prior to using SMC products, please read and understand the warranty terms and disclaimers noted in the specified catalog for the particular products.

***2) Vacuum pads are excluded from this 1 year warranty.**

A vacuum pad is a consumable part, so it is warranted for a year after it is delivered.

Also, even within the warranty period, the wear of a product due to the use of the vacuum pad or failure due to the deterioration of rubber material are not covered by the limited warranty.

Compliance Requirements

1. The use of SMC products with production equipment for the manufacture of weapons of mass destruction (WMD) or any other weapon is strictly prohibited.

2. The exports of SMC products or technology from one country to another are governed by the relevant security laws and regulations of the countries involved in the transaction. Prior to the shipment of a SMC product to another country, assure that all local rules governing that export are known and followed.



Series ZSE10(F)/ISE10 Specific Product Precautions 1

Be sure to read before handling.

Refer to back pages 1 and 2 for Safety Instructions and Handling Precautions for SMC Products (M-E03-3) for Precautions.

Handling

Warning

1. Do not use pressure sensors with corrosive and/or flammable gases.

Caution

1. Do not drop, bump, or apply excessive impacts (100 m/s²) while handling. Although the body of the sensor may not be damaged, the internal parts of the sensor could be damaged and lead to a malfunction.
2. The tensile strength of the cord is 35 N. Applying a greater pulling force on it can cause a malfunction. When handling, hold the body of the sensor—do not dangle it from the cord.
3. Avoid repeatedly bending or stretching lead wires. If the lead wires are routed in such a way that repetitive bending stress or tensile strength is applied, it may cause them to break. When the lead wire is moving, secure it near the switch of the unit. The minimum bending radius is approximately R40 to 60 mm or more. Consult with SMC for details.
4. Do not exceed the screw-in torque of 1 N·m or less for the M5 female thread type after tightening approximately 1/6 of a turn, and 7 to 9 N·m for R1/8 and NPT1/8 type. Exceeding this value can damage the product. Also, the wrench should be applied to the metal part integrated with piping (connected attachment). Applying the wrench to other parts may lead to damage to the product.

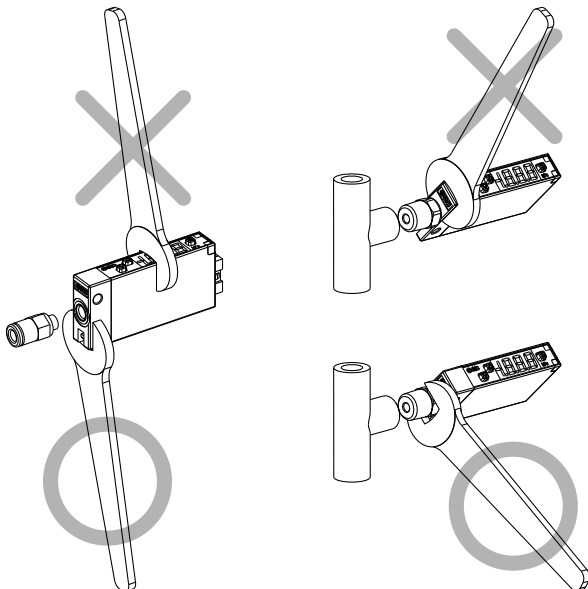

M5 female thread type

R1/8, NPT1/8 type

5. Allow a sufficient margin of tube length in piping in order to prevent application of torsional, tensile or moment load to the tubes and fittings.
6. When a brand of tubing other than SMC is used, make sure that the tolerance of the tube's O.D. satisfies the following specifications.
 - 1) Nylon tubing: within ± 0.1 mm
 - 2) Soft nylon tubing: within ± 0.1 mm
 - 3) Polyurethane tubing: within $+0.15$ mm, within -0.2 mm

Back page 3

7. The applicable fluids are air, non-flammable gas, and inert gas. Consult with SMC if the switch is to be used with other types of fluids.

Connection

Caution

1. Incorrect wiring can damage the switch and cause a malfunction or erroneous switch output. Connections should be done while the power is turned off.
2. Do not attempt to insert or pull the connector when the power is on. A switch output malfunction may occur.
3. Wire separately from power lines and high voltage lines, avoiding wiring in the same conduit with these lines. Malfunctions may occur due to noise from these other lines.
4. If a commercial switching power source is used, make sure that the F.G. terminal is grounded.

Operating Environment

Warning

1. Our pressure switches do not have an explosion proof rating. Never use in the presence of an explosive gas as this may cause a serious explosion.

Caution

1. Our pressure switches are CE marked; however, they are not equipped with surge protection against lightning. Lightning surge countermeasures should be applied directly to system components as necessary.
2. Do not use in an environment where static electricity can cause problems, otherwise system failure or malfunction may result.

Mounting

Caution

1. Mounting with panel mount adapter

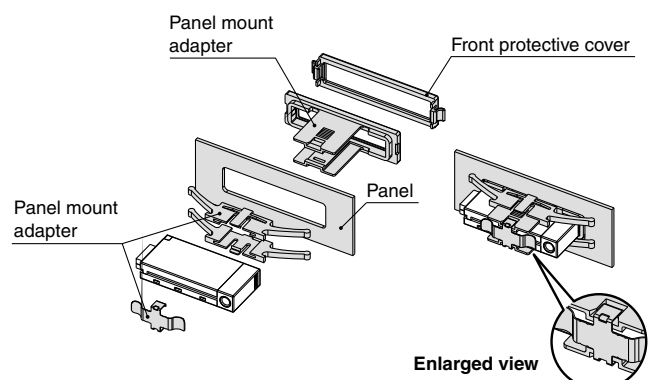



Series ZSE10(F)/ISE10 Specific Product Precautions 2

Be sure to read before handling.

Refer to back pages 1 and 2 for Safety Instructions and Handling Precautions for SMC Products (M-E03-3) for Precautions.

Mounting

⚠ Caution

2. Removal and mounting of DIN rail

- It is necessary to prepare a DIN rail adapter for the mounting of the DIN rail.
- Take care not to bend the claws of the DIN rail adapter when mounting.

Mounting of DIN rail adapter

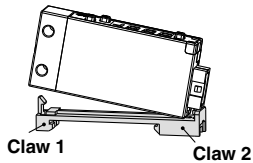

Engage **claw 1** of the product with the upper part of the DIN rail and press it downward, then fit **claw 2** of the product horizontally until it clicks.

Mounting of DIN rail

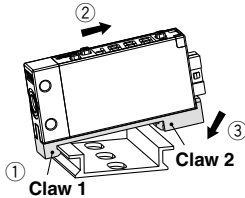

Engage **claw 1** of the product with the DIN rail as indicated by ① and pull it to the direction ②, and then fit **claw 2** of the product horizontally until it clicks.

- We recommend using an end plate available from the manufacturers shown on the right for mounting onto the DIN rail. For the handling and other detailed information about the end plate, contact the manufacturer directly.

Manufacturer	Model
OMRON Corp.	PFP-M
IDEC Corp.	BNL6

Removal of DIN rail

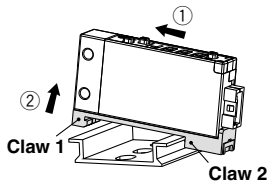

Move to the direction ①, and remove **claw 1** as indicated by ②.

3. Mounting of screws

- The tightening torque of the M3 mounting screw must be 0.5 to 0.7 N·m.
- Do not apply force to the body of the product by mounting. This may lead to damage to the product.
- Mount the product on a flat, even surface. Mounting on an uneven surface can damage the case.

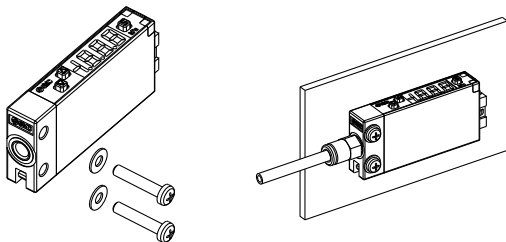

- For piping specifications of O1 and N01, close mounting cannot be applied because of interference between fittings.
- For direct mounting or close mounting, select the fitting with a wrench flat and ϕD of 10 mm or less.

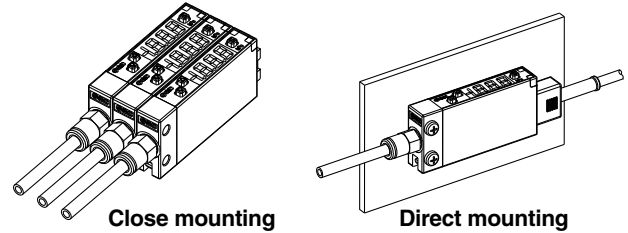

Recommended fittings

- One-touch mini Hexagon socket head male connector: **KJS04-M5** (Tubing O.D. $\phi 4$, Connection thread M5 x 0.8)
- One-touch fitting Hexagon socket head male connector: **KQ2S04-M5** (Tubing O.D. $\phi 4$, Connection thread M5 x 0.8)
- When selecting other fittings, check that there is no interference with surrounding equipment and enough space for maintenance. (For the details of the fittings, refer to SMC Best Pneumatics No. 6.)

Connection/Removal of Connector

⚠ Caution

- To connect the connector, insert it straight while pinching the lever, and then push the lever into the jack of the housing and lock it.
- To remove the connector, pull it straight out while applying pressure with your thumb to the A part (lever) and unhooking it from the jack.

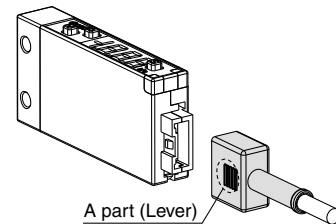

- Do not attempt to insert or pull the connector when the power is on. A switch output malfunction may occur.

Piping

⚠ Caution

- Cut the tube perpendicularly.
- Hold the tube and insert it into the one-touch fitting carefully and securely all the way to the bottom.

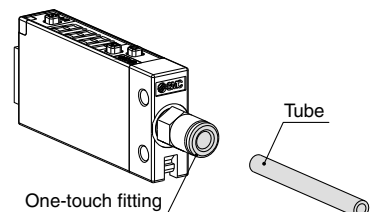



Series ZSE10(F)/ISE10

Specific Product Precautions 3

Be sure to read before handling.

Refer to back pages 1 and 2 for Safety Instructions and Handling Precautions for SMC Products (M-E03-3) for Precautions.

Set Pressure Range and Rated Pressure Range

⚠ Caution



Set the pressure within the rated pressure range.

The set pressure range is the range of pressure that is possible in setting.

The rated pressure range is the range of pressure that satisfies the specifications (accuracy, linearity, etc.) on the switch.

Although it is possible to set a value outside the rated pressure range, the specifications will not be guaranteed even if the value stays within the set pressure range.

Switch		Pressure range				
		-100 kPa	0	100 kPa	500 kPa	1 MPa
For vacuum pressure	ZSE10	-101 kPa	0			
		-105 kPa	10 kPa			
For compound pressure	ZSE10F	-100 kPa		100 kPa		
		-105 kPa		105 kPa		
For positive pressure	ISE10	-100 kPa				1 MPa
		-105 kPa (-0.105 MPa)				1.05 MPa

 Rated pressure range of switch
 Set pressure range of switch

⚠ Safety Instructions Be sure to read "Handling Precautions for SMC Products" (M-E03-3) before using.

SMC Corporation

Akihabara UDX 15F,
 4-14-1, Sotokanda, Chiyoda-ku, Tokyo 101-0021, JAPAN
 Phone: 03-5207-8249 Fax: 03-5298-5362
 URL <http://www.smcworld.com>
 © 2009 SMC Corporation All Rights Reserved

Specifications are subject to change without prior notice and any obligation on the part of the manufacturer.

D-DN

1st printing NR printing NR 6550DN Printed in Japan.

This catalog is printed on recycled paper with concern for the global environment.